

Systematic Innovation



e-zine

Issue 202, January 2019

In this month's issue:

Article – Mediocrity Rules

Article – Safety & Safetyism

The Worst of 2018

Patent of the Month – Hysteresis Bearing-less Motor

Best of The Month – AI Superpowers

Wow In Music – Shine On You Crazy Diamond

Investments – Breath Biopsy

Generational Cycles – Political Impressionability

Biology – Sailfish

Short Thort

News

The Systematic Innovation e-zine is a monthly, subscription only, publication. Each month will feature articles and features aimed at advancing the state of the art in TRIZ and related problem solving methodologies.

Our guarantee to the subscriber is that the material featured in the e-zine will not be published elsewhere for a period of at least 6 months after a new issue is released.

Readers' comments and inputs are always welcome.
Send them to darrell.mann@systematic-innovation.com

Mediocrity Rules



Does anyone remember Douglas Adams' Hitchhiker's Guide To The Galaxy story of the Golgafrinchans and 'Ark B'? Just in case you're not a British person growing up in the 1970s, the Golgafrinchans were a race that got sick of the mediocre people in their midst: "telephone sanitisers, account executives, hairdressers, tired TV producers, insurance salesmen, personnel officers, security guards, public relations executives and management consultants." (Reference 1)

The Golgafrinchan leaders convinced these mediocrities that some sort of doomsday was looming and that they had to get off the planet in a big spaceship. This spaceship was the 'B Ark'. The B-Arkers were assured that the rest of the Golgafrinchan population would follow in the 'A' and 'C' Arks. The A Ark would contain all the excellent people, Golgafrinchans at their best: scientists, artists and such. And the C Ark would contain all the people that did the actual work.

Of course, the supposed A and C Ark people never left because the doomsday story was a cunning ruse. The Golgafrinchan leaders thought they were being clever by getting rid of an entire mediocre, useless third of their population. But then, in an ironic twist, the A and C people are wiped out in an actual Doomsday event. One triggered, in true Douglas Adams fashion, by a disease that spread through unsanitary telephones.

So, as it turned out, only the B Ark people actually survived. A case of survival of the mediocre. Then, by way of a final twist, Douglas Adams' coup de grace sees the B Ark landing on Earth. And that we are now the living descendants of the B Ark people. We are, in other words, evolved from mediocrity. Which would explain an awful lot.

Or, at least it would if we dig a little bit deeper to understand that there are two different kinds of mediocrity. One type that we might think of as 'soft' mediocrity, and one that we might think of as 'hard'. Most of Adams' examples – telephone sanitisers, management consultants, etc – are the 'hard' version of mediocre. 'Soft mediocrity' is all about mediocre performance in domains where A-Ark excellence is actually possible on one end of the performance spectrum, and error-free correct, reliable C-Ark useful performance is possible at the other. A mediocre chess player, or a sloppy assembly line worker, for example, both exhibit soft mediocrity, because both excellence and error-free play are achievable and meaningful.

Hard mediocrity, on the other hand, is performance in domains that are open and messy. Domains like 'telephone sanitization' and 'management consultancy' where there is no prevailing notion of excellence or correct, automatable low-end performance at all. Although he doesn't make the hard/soft distinction, 'hard' mediocrity include all the domains author David Graeber characterises as "bullshit jobs" in Reference 2. There is only one way to be a telephone sanitizer, account executive, middle manager or TV producer: a mediocre way.

You may be wildly successful and make a lot of money in these domains, but your success has little or nothing to do with meeting clear standards of excellence or error-free functioning. You may pursue some sort of Zen-like ideal of unacknowledged excellence, but if you do, it will seem arbitrary and even eccentric to everyone around you. The point of these jobs is mostly optionality. And mediocrity is the rational performance standard in such domains.

These domains fundamentally do not support a native spectrum of performance where excellence is meaningful, because nobody really cares enough, and because the boundaries are too messy. And, here's the important thing: what creates excellence is not that people are good at something, but because people *care enough* to be good at something. That they have 'skin in the game'.

On the other end of the A-C Ark spectrum, what creates repeatable, error-free performance is not that people are good at something, but that the definitions are tight enough that "error" is well-defined, and people care about the errors.

That the Earth might be populated by the descendants of the B-Ark was first brought home to me when I was asked to conduct a number of TRIZ workshops with the Treasury branch of the British Government. I didn't really know why they had selected TRIZ, so when I first encountered the group of thirty or so senior civil servants, one of my first questions was 'what would they normally do whenever they encountered a problem?' I thought I'd hear expressions like brainstorming and system-analysis and value-stream-analysis. Instead, I got silence. At first I thought it was just too early in the day to expect people to interact. Or maybe they hadn't heard me. After I'd allowed the silence to extend into the embarrassment zone, I thought I'd better start giving the delegates a few clues. Where we ended up was that about 10% of the people in the room had *heard of* brainstorming. It was almost like the Treasury had deliberately employed people who showed precisely zero interest in creativity and innovation. Now, one argument might then go, maybe we don't want creativity in the Treasury. I would have some sympathy with that view, but over the course of the next decade gradually encountering other parts of the Government, it became clear that 'being creative' was not good for your career.

If the Earth as a whole isn't populated by B-Ark survivors, in my experience of the British Government, and the senior leadership teams in most of the organisations I visit, very definitely is.

And this is a problem from an innovation perspective.

Not least of the reasons being that, as Douglas Adams' parable reveals, the B-Ark people are quite resilient. Once they take the reigns of an organisation it takes quite a lot of effort to displace them. Something like (fingers-crossed) a societal crisis... of which there seem to be quite a few brewing at the moment.

I often find that thinking through a situation in 2x2 matrix term is beneficial. Partly because it forces some creative thinking to find the right labels for the four different quadrants, and partly because it helps identify the key contradiction to be solved. Here's how I think Adams' Golgafrinchan society works as a 2x2 matrix:

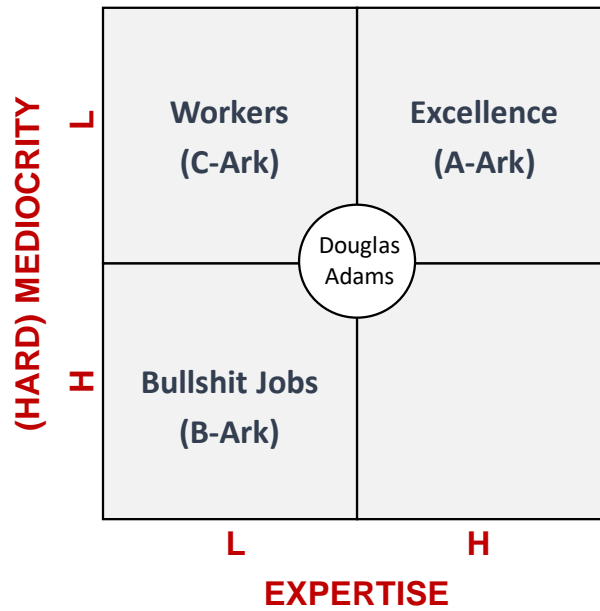

Figure 1: Golgafrinchan Society As A 2x2 Matrix

A part of the creative thinking challenge here is recognizing that, because there were only three arks in Adams' parable, we're left with a gap in the model. Who are the, bottom-right, high-expertise-high-(hard)-mediocrity members of society?

It took me a while, but I've finally concluded it is the person who decided to gain some theoretical expertise and then successfully did so. It is the college graduate. The person full of book knowledge, and empty of a realistic knowledge of how the world actually works: high 'expertise', high mediocrity. Once I'd made that connection, it then became possible to plot a typical life trajectory. The naïve young graduate starts in the bottom-right quadrant and then follows the blue arrow:

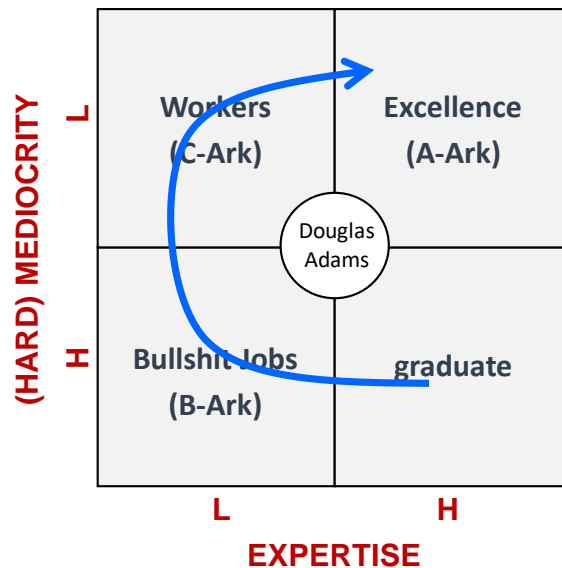

Figure 2: Typical Life Trajectory

Graduates inherently get recruited by B-Ark people, because these are the people that work in HR. The poor, gullible graduates, once they become 'employees', quickly learn that if they are to survive, the need to become B-Ark people too. They realise the work they've been given is bullshit work and turn off their knowledge accordingly. A lot of graduates, in my experience, decide to stay here. If they don't, they migrate into the C-Ark world. Where they quickly learn that, if nothing else, being on the C-Ark is better for your mental health. At least you get to go home at the end of the day safe in the knowledge that you're now contributing something that is actually useful to society. C-Ark people also get to appreciate not only how the real-world works, but how they might help create something better. They need to build a different kind of expertise, and they need to put some skin in the game. Once these realizations appear, our rapidly greying graduate now has the possibility to join the A-Ark. Where they will be in a tiny minority. No doubt frustrated at what they see over in the B-Ark...

...the B-Ark, being the place where the money is. Or the easy money at least. If you're looking for work-life balance and want a materially-rich life, the B-Ark is pretty much the place to be.

From a societal health perspective, this is not a good thing. It is the reason citizens of the United Kingdom currently find themselves living through the running joke that Brexit has become. B-Ark politicians negotiating B-Ark solutions ('Brexit means Brexit'). The sting in the tail – the killer sting in the tail – is that Adams' parable tells us the B-Ark population is the only one that survives. Charles Darwin's theory of evolution talks about survival of the fittest. What the Golgafrinchan story reveals is that, for the most part, 'fittest' seems to correspond to those that are the most mediocre.

How's that for a candidate good contradiction for A- And C-Ark citizens to work on? The mission is clear. We need to build an Ark. An Ark for all the B Ark people. And then we need to tell them about the coming Doomsday...

References

- 1) https://hitchhikers.fandom.com/wiki/Golgafrinchan_Ark_Fleet_Ship_B
- 2) Graeber, D., 'Bullshit Jobs: A Theory', Allen Lane, May 2018.

Finding a good contradiction is often the trigger for some important learning. Let's see if that might be the case by examining one of the three great Untruths discussed in the 'Coddling...' book. The Nietzsche aphorism, "What doesn't kill me makes me stronger" has, since 2013 been reversed by many parents, teachers, school administrators, and students themselves to now read, 'what doesn't kill you makes you weaker'. They have bought into a myth that students and children are inherently fragile. For the most part, this represents an understandable desire to protect children from emotional trauma. But overwhelming evidence suggests that this approach makes kids less psychologically stable. By over-sheltering kids, Lukianoff and Haidt show us, we end up exposing them to more serious harm when they eventually encounter a situation where parents and teachers don't step in to protect them.

On the other hand, taken literally, Nietzsche's famous aphorism is not entirely correct. Some things that don't kill you can still leave you permanently damaged and diminished.

So where does that leave us? As shown on the physical contradiction defining right hand side of Figure 1, safety is both good and not good. Drawn graphically, physical contradictions look like u-shaped or parabolic graphs. Here's what that graph looks like when we plot the relationship between safety measures and the safety those measures do or don't produce:

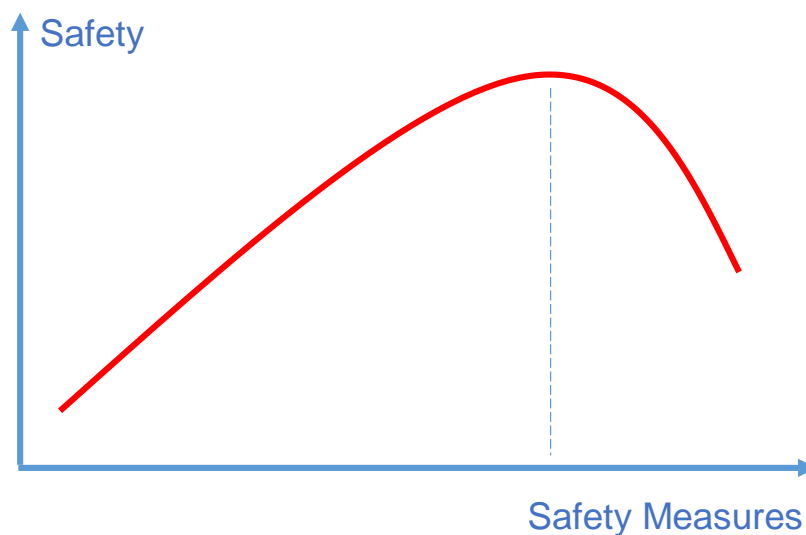

Figure 2: Safety Measures & The Effect They Have On Safety

What this curve tells us is that, at first, adding more safety measures has a positive effect on safety, but then after a certain point, adding more safety measures causes safety performance to decline. We see a classic example of this with pedestrian safety on our roads: providing people with specific places to cross busy roads like zebra-crossings reduces the number of cars hitting pedestrians, but then when the state introduces jay-walking laws, puts traffic-lights and cameras onto the crossing, safety goes down again. Putting up a handrail makes staircases safer; putting up signs telling people to hold the handrail makes safety go down again. By adding 'too much' safety advice, you end up turning people into unthinking idiots.

The graph begins to help solve the more-and-less safety contradiction. My 'nanny-state' article is all about the left-hand-side of the picture. People like Jamie Oliver, like him or not, is trying to tell us important stuff about eating more healthily. If we listened to him rather than the corporate-sponsored media seeking to ridicule him, we'd all be safer. What Lukianoff and Haidt describe in their academia horror story is all about the right hand side

of the curve – the ‘what doesn’t kill you makes you weaker’ pronouncements of well-meaning liberal academics are counter-productive because they over-protect people by turning students into unthinking idiots.

Actually, the story is a little more complex than that. A significant part of the ‘Coddling...’ story is about emotional safety rather than physical safety. And when we distinguish specifically between the two, we get a graph that looks like this:

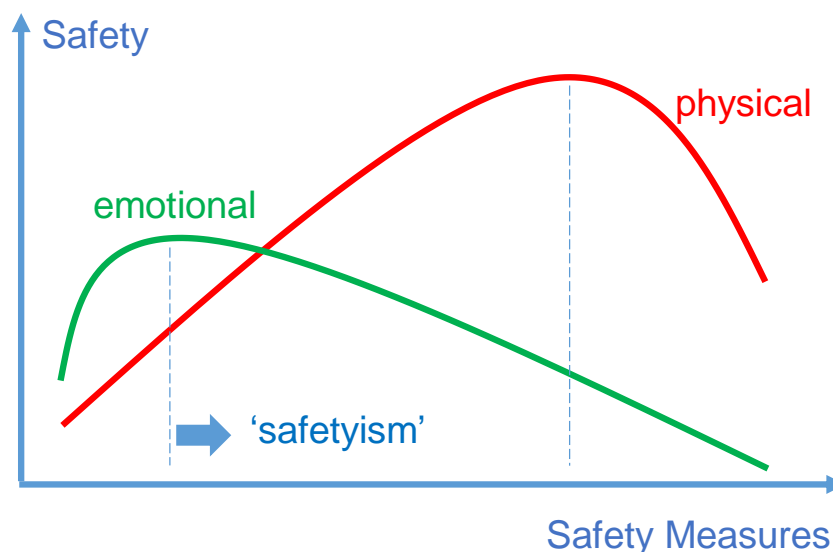

Figure 3: Relative Safety Measure Impact On Emotional And Physical Safety

Emotional safety (the new green line on the graph) also follows in increasing-decreasing trajectory but this time the peak position is at a much lower level of safety measure than it is for physical safety. Having ‘some’ level of emotional safety measures in place is a good idea, but it is very easy, as we’re seeing in academia right now, to over-egg the pudding.

By way of an example of how ‘some’ emotional safety is a good idea, I’m reminded of the time the thirteen-year-old version of my sister found herself watching *The Exorcist* with some of her school friends. She spent the next two weeks sleeping in my mum’s bed, afraid to be alone at night. Horror movies carry 18 Certificates for a good reason. But go much beyond that and we fall into the ‘what doesn’t kill you makes you weaker’ trap, emotionally speaking. Over-protect people by giving them ‘safe spaces’ to retreat from speakers with controversial opinions about the world and you make them very fragile. So that when they’re released into the big wide world they have no coping skills. Wrap people in emotional cotton-wool and you make them emotionally very fragile. This is what ‘safetyism’ is all about: trying to impose more safety measures when we’re past the peak of the curve.

And so, the safety-and-no-safety physical contradiction becomes quite easy to solve. We solve it on condition: If the current safety measures are below the safetyism peak, adding more is a good idea; if we’re beyond the peak, adding more is a really bad idea.

References

- 1) <http://darrellmann.com/nanny-states/>
- 2) O’Brien, J., ‘How To Be Right... In A World Gone Wrong’, WH Allen, 2018.
- 3) Lukianoff, G., Haidt, J., ‘The Coddling Of The American Mind: How Good Intentions And Bad Ideas Are Setting Up A Generation For Failure’, Allen Lane, 2018.

Worst of 2018

Finding bad things to write about increasingly feels like shooting large fish in small barrels with large Howitzers. That said, 2018 felt a bit like a year of flux. The focus of the rubbishness is shifting. Customer service seems to be getting better and fewer truly awful patent applications are making it through the system. That's one side of the equation. On the other, it's been a bit of a humdinger of a year as far as new product screw-ups from companies who really should know better, and advertising messaging that comes across as increasingly desperate. Or deluded.

All that said, we've still managed to find winners in each of our five categories. Starting with...

Joint 'It-Can't-Be-KLM-Again Suck'y-Airline Of The Year' and 'All-Conversations-May-Be-Recorded-For-Training-Purposes Customer Service' Awards – I'm not sure whether being a British citizen (or should I say, 'subject', which I officially am) makes me a 'customer', but I am pretty certain that the British Government keeps telling me I am and that they're there to serve my needs. In which case, there was never going to be much doubt over who was going to win this award in 2018. It was either going to be the Government or the Labour Party Opposition for their respective roles in the absolute debacle that is Brexit. By combining the two together, shall we just say that the Award winner is the British Parliament? To paraphrase a noble parliamentarian of old, 'never in the field of human conflict were so many let down by so few'. No critical thinking skills. No creativity. Just lies, mistruths, mis-direction and political point scoring. I've spent the year, basically, being embarrassed to be British wherever I go. I've also spent far too much time blogging about the dismal state of thinking instead of doing all the things that were on my jobs list for the year. Maybe that's a blessing: 13 fewer Darrell books? I don't know any more.



All I do know is that the whole thing was encapsulated beautifully for me during the now famous live Sky News interview with dull-witted-but-mostly-harmless Conservative MP, Anna Soubry. In the background, out of sight thanks to the fact that all the TV companies have had to build 20-foot-high platforms, are a bunch of yellow-vested (thanks, France, for that meme) thugs. At the time, the media furor that followed the incident missed the nugget. If you listen again to what's happening in the background, you here this:

Yellow-Vest-Numpty-Ringleader (shouting): 'What do we want?'
(confused silence)

2nd Yellow-Vest Numpty (not the ringleader) (singing): 'Soubry is a Nazi.'

All the Yellow-Vest Numpties together in chorus, singing: 'Soubry is a Nazi, Soubry is a...'
Continue ad infinitum.

How low can we go? Rest assured, the politicians haven't finished 'serving' the population yet. We've yet to reach rock bottom. In other words, from where I sit right now its difficult to imagine any other 'service provider' ever taking this award away from Parliament.

The Depeche Mode Everything-Counts-In-Large-Amounts Literature Award – The good news: 2018 saw a significant reduction in the number of 'innovation' books published. Down from a peak of around 1600 a few years ago, to a number slightly lower than 700. The bad news: the quality of those books has fallen precipitously. Quite honestly, we could've given this 'Worst Of' award to over half of them. In short, we had a judging panel crisis. Time, we eventually concluded, to bring some actual science to the down-select process. Thinking caps on, we came up with five criteria we could use to determine whether a book had anything useful to contribute to the state of the innovation art:

- 1) Did the authors understand what 'innovation' means?
- 2) Did the authors understand complexity?
- 3) Did the authors understand contradictions?
- 4) Did the authors understand confirmation bias (and that basing a theory on one-case-study is not statistically significant)?
- 5) Did the authors understand the customer say/do gap?

Here's how some of the award candidates fared when compared against these metrics. As in previous years, we tried to avoid 'Kindle-only' 'books' because 99 times out of a 100 they're on Kindle because either no actual publisher would touch them, and/or the author is a delusional maniac who believes that opinion is the same as fact. Usually both.



Book	Understands 'innovation'?	Understands Complexity?	Understands Contradictions ?	Understands Confirmation Bias?	Understands Say-Do Gap?
Living Innovation	No	No	No	No	No
Horizon Scanning Innovation	No	No	No	No	OMG
New Waves In Innov. Man. Res.	No	No	No	Pitiful	No
Navigating Innovation	No	No	No	No	No
Innovative Business Management Using TRIZ	No	No	You would hope 'yes', but... No	No	No
Lean Development & Innovation	No	No	No	Kind of	No
Applications Of Conscious Innovation	No	No	No	You would hope 'yes', but... No	You would hope 'yes' but... No
A to Z Of Innovation Management	No	No	No	No	No
Art And Business	No	No	No	No	Kind of
Open Innovation Business Modelling	No	No	No	No	OMG
Open Innovation Ecosystems	No	No	No	No	No
World Scientific Ref. On Innovation	No	No	No	No	No

You get the point: bringing science to the judging panel didn't help. The analysis did, however, reveal something else. A price/quality inversion: the more expensive the book, the less useful it will be. Extreme example: the four volume, \$300+ 'World Scientific Reference On Innovation', which is so laughably bad I actually came to admire the authors. A good book is all about pacing, and to make each volume funnier than the previous one really takes some doing. You know that Jim Carrey, Kate Winslett film where there's a way to erase specific memories? This book was like that machine. If you knew something about innovation at the beginning, you're guaranteed not to know anything about innovation by the time you reached the end. Academia and innovation, it seems, don't make for a good match.

Anyway, we haven't even reached the award winners yet. As in previous years, it was difficult to home in on a single title, so we allowed ourselves the luxury of awarding a pair of joint winners, so congratulations...

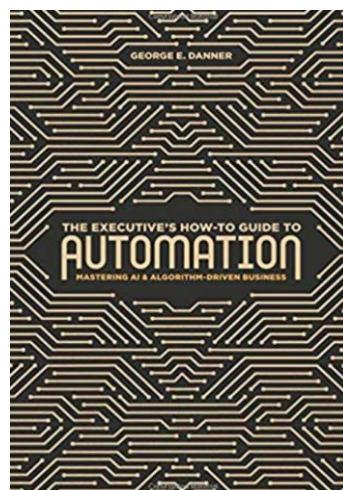
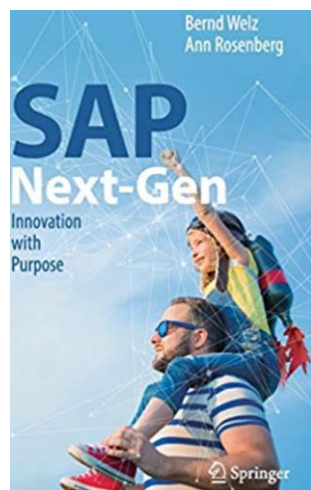

Note for future reference: if you see an innovation book with the word ‘Springer’ on it, it’s the same as the health warning on cigarette packets. Your arteries won’t *actually* clog up if you read SAP Next-Gen, but it will feel like they have. Bernd Welz and Ann Rosenberg’s book is very Orwellian. In Orwell’s book 1984, ‘The Ministry of Truth’ is all about lies; the Ministry of Defence is all about war. In Welz and Rosenberg’s world, ‘Innovation With Purpose’ is all about how to do the precise opposite of innovation. SAP, of course, has a vested interest in ensuring none of their clients ever innovates. Theirs is the ultimate command-and-control business model. By offering copies of this book containing the word ‘innovation’ they get to appease the increasing army of clients claiming SAP is impeding their ability to innovate, while at the same time virtually guaranteeing those clients never will be able to innovate ever again. On some levels it is pure genius. Just the wrong kind.

Which kind of leads us to the other joint winner, ‘The Executive’s How-To Guide To Automation’. On the face of it, this doesn’t sound much like an innovation book at all. In theory, automation and ‘algorithm driven’ should be the precise opposite of innovation. But that’s where author George Danner pulls off a jaw-dropping double bluff. Automation by ‘mastering AI’ is innovation. Managers don’t need scientists and engineers to innovate anymore, because all management need to do is work out what the algorithm for running the business more efficiently is, and hey-presto, you’re done. Well, yes, you probably are done. Just not in a good way.

The world of management is really struggling when it comes to innovation. I’m still referring to Gary Hamel’s ‘The Future Of Management’ in a lot of my workshops, and how it was trying to let leadership and management communities know that it was time to step up and bite the innovation bullet. That was 2007. All that’s happened since then is the leaders and managers of the world appear to be even further away from understanding the ‘I’ word, and the level of frustration of the innovators working underneath them has, as a consequence, reached stroke-inducing levels. George Donner’s epic mis-step basically says to leaders and managers that its now really easy to relieve that frustration – just get rid of the innovators and replace them with code. If you didn’t know any better you might conclude that Danner was being sponsored by SAP and the Ministry Of Innovation. It wouldn’t surprise me.

The Necessity-Is-Not-Always-The-Mother Invention Award – I was determined to stay away from pet’s corner for this year’s patent awards. Turns out, though, that it is now just about the only place still left to go where the USPTO still allows themselves the luxury of a joke or two. That certainly seems part of the rationale for these three:

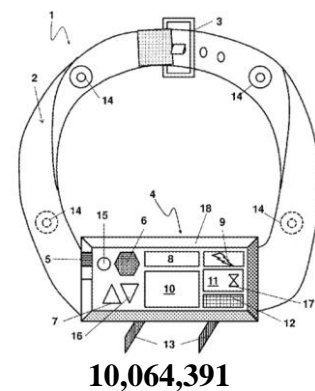
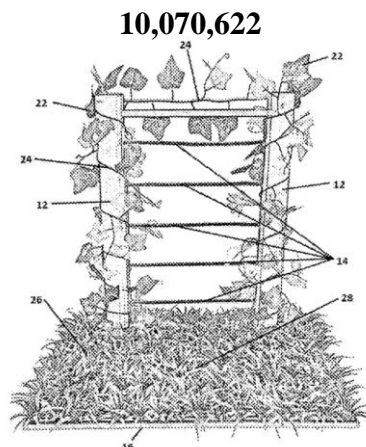
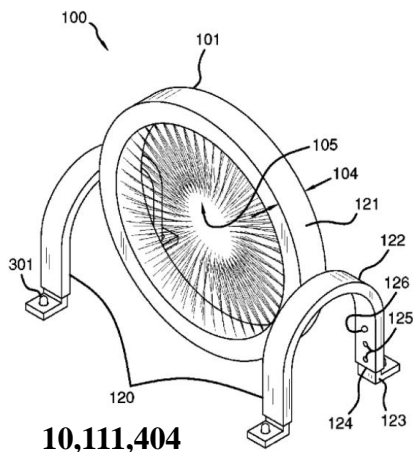

Working our way from left to right, first up we have 'Pet Grooming Tunnel'. Here's what the New York state based lone inventor has to say about it:

The pet grooming tunnel is constructed of a ring member that includes a plurality of brush bristles provided on an inner surface. The ring member is supported in a vertical orientation via support legs provided on opposing sides of the ring member. The support legs are each vertically, adjustable so as to raise and lower the ring member with respect to a support surface. The plurality of brush bristles are concentrically oriented. An alternative embodiment includes a wider ring member wherein the plurality of brush bristles form a truncated conical opening.

I get it. It's the cat version of those machines they use to compress Christmas trees so they fit in your car. Only, I expect the tree, however, will be more willing to enter the 'tunnel' than my cat. Give it a push. You know the poor wee mite is going to enjoy it eventually. Now make them run around in a circle and jump through the hoop again. And again. After which, you get out your usual brush and use that to groom the 90% of cat fur not groomed by the tunnel. That's saved us all a job then.

Next, in the middle is 'Nature side cat relaxation center and scratcher'. Sounds good so far. The abstract is the clincher:

The invention is used for by a pet or cat to scratch their face and claws independently while utilizing an area on the product to relax. The present invention consists of two poles, each in a vertical position that will be attached and secured on a base. The base will also serve as a relaxation lounge area where it will have an appearance of a natural garden and lawn that is attached. The poles will have attached to them the main component which is the face scratcher. There will be multiple face scratchers attached to the poles ranging from top to bottom giving different levels of scratching. To add to the nature feeling of the product, leaves and vines will be wrapped around the poles and also serve as an additional scratcher.

I don't think I need to say any more on this one. It's the Mono-Bi-Poly trend for cats.

Finally, on the right we have a 'behaviour deterring collar'. I'm pretty certain there have been multiple similar inventions in the past: doggie poops in your shoe, tighten the collar to restrict airflow, and hey presto, Rover learns to poop in someone else's shoe next time. US10,064,391, however, picks up on a potential problem with this basic idea. What happens if the dog keeps offending and the collar keeps tightening? Tricky. But now no longer a problem because the invention incorporates a smartphone app triggered 'emergency override'. So now, when the owner recognizes that Rover is turning blue and appears to have stopped breathing, all they need to do is press the virtual emergency override button. Dog lives. And no more poop in anyone's shoes.

Meanwhile, I think our eventual winner in the pet category is this little gem from – surprise – another lone inventor. Again from New York. There must be something in the water in that part of the world. Here's the main picture:

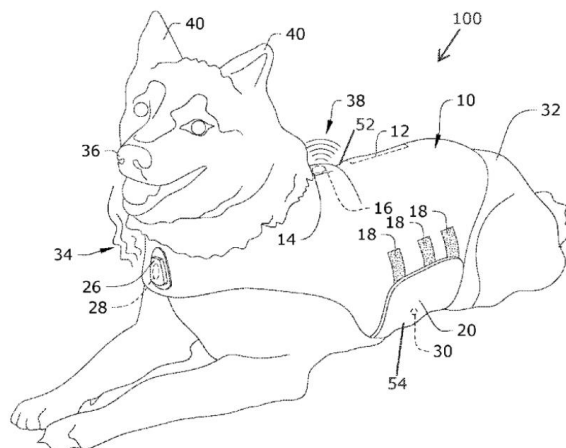

The invention is the vest. US10,070,621 is the number. Here's the abstract:

A pet anxiety apparatus is provided. The pet anxiety apparatus embodies a compression vest providing scent, vibrational and audio components. The compression vest may be moved between a disengaged, unwrapped condition and an engaged, wrapped condition imparting the sensation of a hug to the pet animal wearing the pet anxiety apparatus. In the engaged, wrapped condition, a scent emitter is disposed directly downward of the pet's nose, while an audio output device is disposed along the animal's spinal near its ears, thereby providing tactile, scent, and audio...

Honestly, until I read the next word, I really wasn't certain whether the invention was intended to *make* pets anxious, or *prevent* them from becoming anxious. It's actually intended to be therapeutic, but I really think this one could go either way. This is how far the world has descended in the last year (the application was processed by the USPTO in an eye-wateringly fast 8 months... always a sign of an important invention). We're now all so screwed-up, we're even making our pets anxious. Snowflake cats and snowflake dogs. Personally, meanwhile, I'm thinking of sticking a variant of this patent into the system for this year's crop of first year undergraduates, several of whom, I'm pretty certain would benefit from their own anxiety vest. Only joking.... Breathe... in... out... smell the lovely lavender.

Okay, so now to the non-pet world. Not nearly so funny, sadly, but what these next two lack in humour they make up for in weirdness. With maybe a touch of insanity thrown in for good measure.

First up is piece of literally literal thinking from a lone inventor (duh!) in Scottsdale, Arizona:

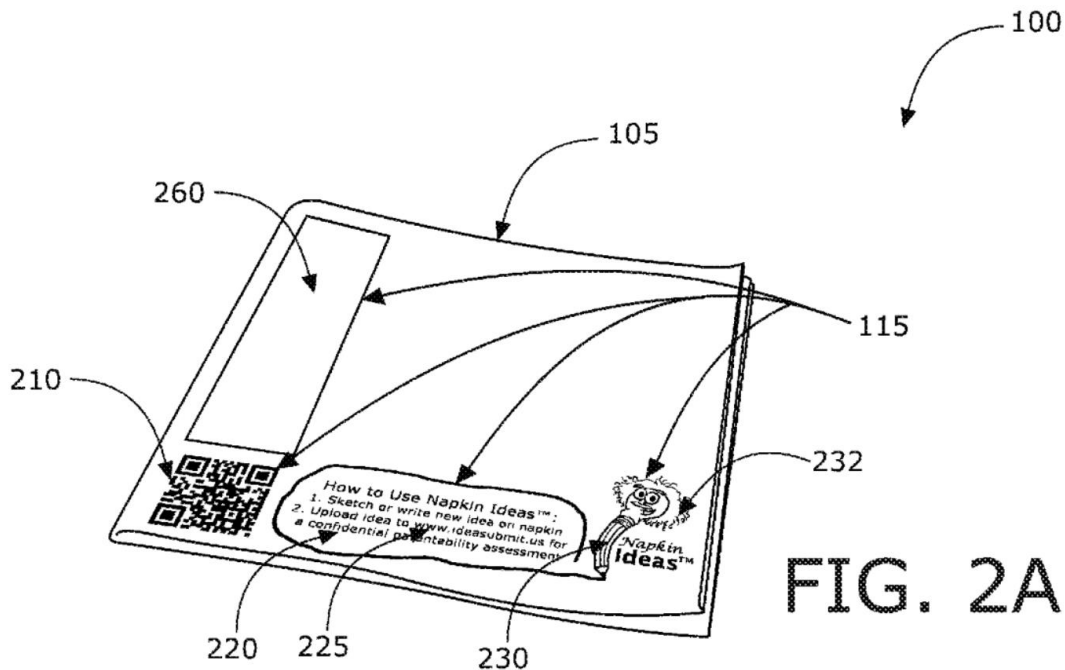

Remember that time when you were in a restaurant and you'd just invented South West Airlines? And you needed to sketch it out on something real quick? Any piece of paper will do. Aaargh. Just give me *something* before I lose the idea. So, what do you end up using? Out of sheer desperation, the napkin of course. The famous napkin. Subsequently the source of a book of how to invent stuff on napkins. It's almost like the napkin does the inventing for you. Well, US10,074,062, as it turns out doesn't quite do that for you. But it does allow you to ping your next unicorn idea straight to the USPTO. Well, almost. Invent something brilliant, sketch it on the napkin, take a photo of it, and the QR code automatically uploads it onto a secure, date-and-time stamped database of unicorn ideas. Boom. Idea safe.

When I'm in my happy place I like to think of Robert Jeffrey Herman, the inventor of this idea. He's in a restaurant. He's just had the idea for a napkin with a QR code on it that sends the idea to a safe database. It's brilliant. But if he doesn't find something to write on, he's going to lose it. Quick. He reaches for a napkin. He writes down the idea. And reaches for his camera.... Damn. So close, and yet so far. Robert Jeffrey Herman, like everyone else in this situation, puts the scribbled-on napkin in his pocket and heads for home, buzzing with excitement. When he arrives, he carefully takes the napkin out of his pocket, puts it in a frame, and hangs it on the wall. Three cheers for Mr Herman.

Okay, last and not least, time to head to the Netherlands for a change. Still a US patent though: US10,016,327. Here is lone inventor, Rolandus Franciscus Beatrijs Marie Josef Hoijing's 'coffin for holding an inner coffin and having a base and a cover':

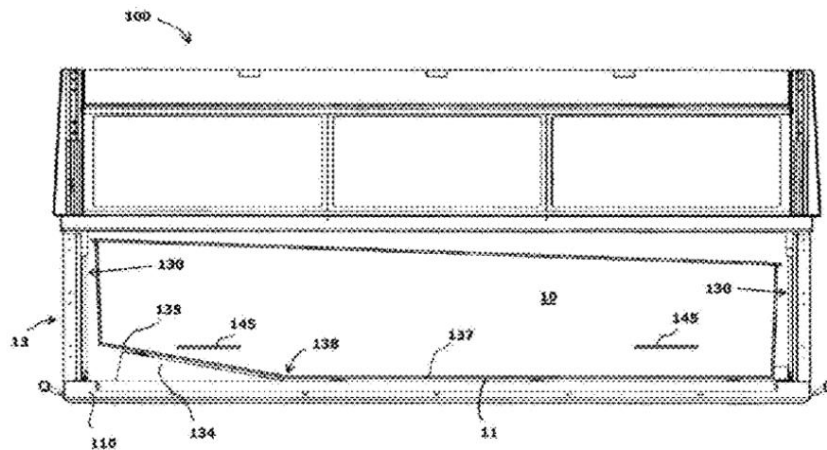

Now, if I was looking for great examples of Inventive Principle 7, I'd be right there outside Rolandus Franciscus Beatrijs Marie Josef Hoijing's front door, on my knees pleading for him to tell me he used TRIZ to come up with his invention: thing we want to improve – corpse; thing preventing us from making the improvement – air. Solution: Principle 7. On the other hand, nesting coffins inside other coffins sounds slightly sinister to me. Especially when, after reading the background part of the patent document, it appears the primary motivation is that one of the nested coffins is 're-used'. Please, God, let it be the outer one.

The Slow-Fast-Moving-Consumer-Goods Design Excellence Award – 2018 was another not-so-stellar year for anything coming out of Apple, Facebook or Google. Pointless incrementalism or really-expensive-doesn't-work-ism usually being the verdict of customers. The world of technology, it seems, is struggling. Take this monstrosity:



A \$1000 clothes folder. A \$1000 clothes folder the size of a small house. That beast is a lot of clothes folder. Looking at the video of the FoldiMate in action, I think if I was spending that much money and building an extension to accommodate it, I'd expect to be able to simply throw my unfolded garments at it from the other side of the room. In reality, the user basically has to learn how to pre-fold garments before ever so carefully feeding the pre-folded garment into the FoldiMate so it can do the final two folds. You *really* have to hate folding shirts to contemplate this one.

Meanwhile, just as you thought the era of parental over-protection was coming to its end, Fisher-Price launched the 'Sproutling' in 2018. It's a bit like the device fitted to prisoners on remand. Only for one-year-olds. My tip for new or expecting parents: smart baby gadgets are rarely 'smart'. Usually, however, they're at least harmless. Unless you count the emotional scars. The Sproutling managed to compound all of those lifelong emotional scars with a few more near-term tangible ones. Like severe eczema outbreaks. Well, I suppose that'll set the alarm off so mom and dad know the thing works. Except the app is buggy and its alerts are basically useless and, if I believe some of the user reviews, usually false. Better safe than sorry though, helicopter-Dad.

Ultimately, though, FoldiMate and Sproutling pale into significance next to the 2018 UK launch of 'VIPoo', the latest attempt by the FMCG to raise societal bodily-function paranoia to unprecedented new levels.



It's basically a spray that creates a thin layer in your toilet bowl that traps the odors under its surface. The instructions on the bottle advise you spray 3 to 5 drops of the VIPoo directly into the toilet bowl before use, then carry on with your business as normal. Ever heard the expression, 'polishing a turd'? Well, now, thanks to VIPoo, you can make it smell nice too. For everyone else, I've heard that 'water' is another way of masking unpleasant smells. That's kind of the point of the U-bend. It's got water in it so you don't have to smell what's on the other side of the U-bend. But water, of course, doesn't cost £5 a bottle. That's what VIPoo is retailing for. That's how much the makers think your paranoia is willing to pay. To make your shit smell like rose-scented shit. Or 'lemon drizzle'. If you get embarrassed by this sort of thing, you'll no doubt already be carrying around half a dozen travel-size bottles in your briefcase. If £5 a bottle is out of your comfort zone, you can get pretty much the same result using WD-40. And, it turns out, following my scientifically conducted trial, WD40-scented shit smells way better. Another addition to the WD40 Inventive Principles. So at least something good has come out of this.

Let's All Jump Off A Cliff Advertising Suicide Award: An easy one to award this year. If you're a Bradford City fan at least. 2018 wasn't a great year to support the Bantams, the team being pretty much in freefall for most of the year. So, it came as a great relief when arch-rivals, Leeds United decided to 'rebrand'. The club apparently conducted six months of research in consultation with 10,000 people before proudly announcing their new logo to the world via a massive advertising fanfare. This is what they'd come up with:



Leeds supporters were outraged and set up a protest petition within minutes of the announcement. It took about two hours to get over 40,000 signatures (not bad considering that most Leeds supporters can neither read nor write). It then took another four hours before the Club announced they were scrapping the plan. As far as I know, they still haven't worked out that 8000 of the 10,000 people they consulted at the start of the exercise were Bradford fans. You're welcome.

Patent of the Month - Hysteresis Bearing-less Motor

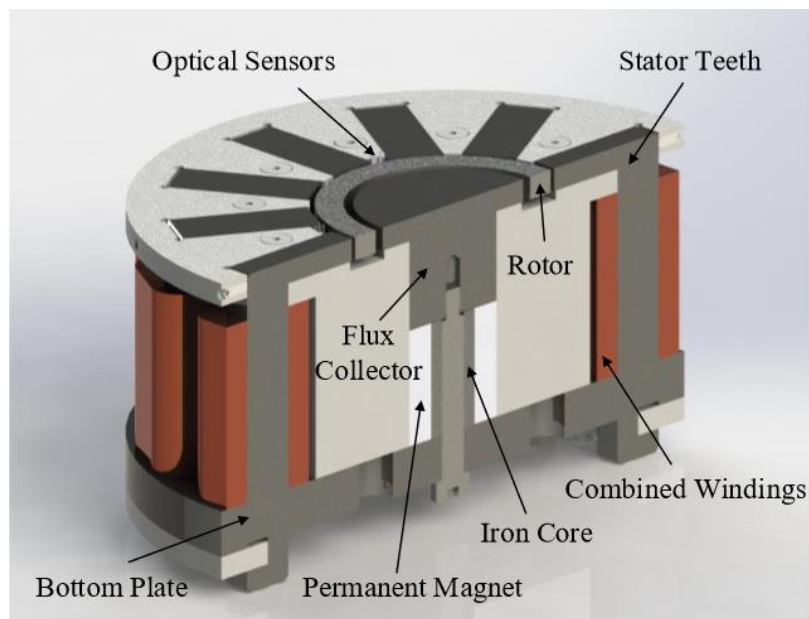

It was a close-run thing for our Patent of the Month award this month. We nearly gave the honour to US10,177,688 from a joint university/industry foundation in Korea. It offers the world the potential for a really simple, very elegant tidal energy collection device. The core of the invention is the deployment of a smart ionic polymer-metal composite that eliminates the need for moving parts. Always a good idea in a device that has to survive hostile environments for long periods of time without any maintenance. So far so good. The only problem is that, while the inventors have solved the difficult problem, all of the peripheral energy conversion stuff makes use of conventional non-seaworthy kit which kind of negates the value of the main inventive steps. Hopefully, if/when they go to the commercialization stage, the transition out of academia and into the ocean, it becomes a very resilient technology. In the meantime, it felt like we ought to award the Patent of the Month to a different team, from another university we've featured several times in this part of the ezine, MIT. Their patent, US10,177,627, was granted on 8 January.

A recent paper published by the inventors is probably more readable than the invention disclosure (you can find a copy here: <https://core.ac.uk/download/pdf/141472834.pdf>). That said, the background section and its description of the problem is kind of coherent for the non-lawyer:

As is known in the art, bearingless motors levitate and drive a rotor with a single stator unit. This approach can eliminate mechanical bearings in a compact form factor.

As is also known, bearingless motor technology has drawn international research efforts, which has led to developments of bearingless motors of various types. Bearingless motors are found to be particularly useful in applications such as blood pumps and pumps for high-purity chemical processes. Bearingless slice motors are particularly suitable for such applications. Bearingless slice motors levitate a pump impeller passively in axial and tilting directions and actively in two radial directions. The passive levitation is realized with reluctance forces generated between a soft-magnetic stator and an impeller comprising a permanent magnet. Active levitation, on the other hand, is realized with feedback control. Gruber et al. (2015) developed a bearingless slice motor that drives a reluctance rotor. In such an embodiment, the magnet is eliminated from the

rotor and placed on the stator to create a homopolar bias flux for passive stabilization of the rotor in axial and tilting directions.

Replacing a reluctance rotor in bearingless slice motors with a hysteresis rotor enables the advantages from hysteresis motors, such as robust and simple rotor construction, smooth torque generation, and smooth transition from asynchronous to synchronous operation. These advantages make the homopolar flux biased, hysteresis bearingless motor described herein suitable for a wide variety of applications including, but not limited to: high-speed rotary applications, ultraclean pumping systems and/or blood pumps that require disposable impeller replacement. The operating principle of a homopolar hysteresis bearingless motor as described herein can be best understood as a combination of a flux-biased magnetic bearing and a hysteresis motor.

With this particular arrangement, an electric drive to pump a fluid by rotating a magnetically-levitated hysteresis rotor is provided. Utilizing homopolar flux biasing decouples the force and torque generations, provides force generation independent of rotor angular position, and provides force/current for suspension which are higher than prior art approaches, and suspension force linearization. Such a pump finds use in a wide variety of applications including, but not limited to, blood pumps, ultra clean pumping systems and high speed rotary applications. Since no mechanical connections (such as bearings and shafts) are involved for the impeller suspension and torque generation, pumps provided in accordance with the concepts described herein impose less stress and heat on a fluid than in prior art approaches. Therefore, pumps provided in accordance with the concepts described herein are particularly advantageous for pumping delicate fluids such as biological samples. Such pumps can thus be used as blood pumps to reduce the level of hemolysis and thrombosis.

If we summarise this by saying reluctance motors solved the 'eliminate lubricant' problem by evolving (per the Dynamization trend) from fluid to field, the new 'hysteresis' motor solves the contradictions that emerge from that reluctance motor technology. Which is that the reluctance motor, in order to deliver the required torque, currently needs a complex arrangement of sub-systems and therefore finds it difficult to achieve good robustness. Here's how that combination might best be mapped on to the Contradiction Matrix:

IMPROVING PARAMETERS YOU HAVE
SELECTED:

Force/Torque (15)

WORSENING PARAMETERS YOU HAVE
SELECTED:

**Strength (20) and Reliability/Robustness
(35) and System Complexity (45)**

SUGGESTED INVENTIVE PRINCIPLES:

**35, 14, 5, 3, 10, 9, 1, 24, 4, 17, 13, 28,
18, 12, 7, 27, 40, 26**

And here, from the paper rather than the patent, is how the invention solves the conflict:

[The figure at the top of this article] shows the design of our bearing-less motor and the prototype system. The stator mainly consists of a bottom plate, twelve stator teeth (Principle 1), twelve combined windings, and a flux biasing structure comprising a permanent magnet and a flux collector (Principle 4). The stator teeth and the flux collector form an annular groove (Principle 3, 14), in which a ring-shaped rotor is inserted. The permanent magnet provides a bias flux through the hysteresis rotor in the radial direction. The level of bias flux can be adjusted with an iron core

inserted into the permanent magnet (Principle 24). The ring-shaped rotor is made of D2 steel (Principle 35), which has some favorable characteristics for our design: First, its permeability is relatively high and therefore advantageous to generate reluctance forces. Second, D2 steel exhibits some level of magnetic hysteresis (Principle 4), which can be utilized to generate a hysteresis torque. The operating principle of a homopolar hysteresis bearingless motor can be best understood as a combination of a fluxbiased magnetic bearing and a hysteresis motor. We next discuss the force generation mechanism of a fluxbiased magnetic bearing as applied to our bearingless motor design:

[The next figure, below] shows across-sectional side view of our bearingless motor. Here, the ring-shaped rotor forms two air-gaps with the stator: an outer air-gap with the stator teeth, and an inner air-gap with the flux collector. The homopolar bias flux (dashed blue lines) from the permanent magnet traverses through the hysteresis rotor radially outwards and returns via the stator bottom plate. As the stator superimposes 2-pole suspension flux (solid red lines), the net flux density in the outer air-gap weakens in area (L) and strengthens in area (R), thereby generating a differential reluctance force on the rotor to the positive x -direction. The direction of the suspension force is determined by the 2-pole flux direction, and the magnitude of the suspension force is determined by the strength of the 2-pole flux. Therefore, by controlling the direction and magnitude of 2-pole suspension flux based on the position measurements, we can actively stabilize the rotor translations in any radial direction. Due to the homopolar bias flux, other degrees of freedom, i.e., translation along the z -axis and tilts about the x - and y -axes, are passively stable.

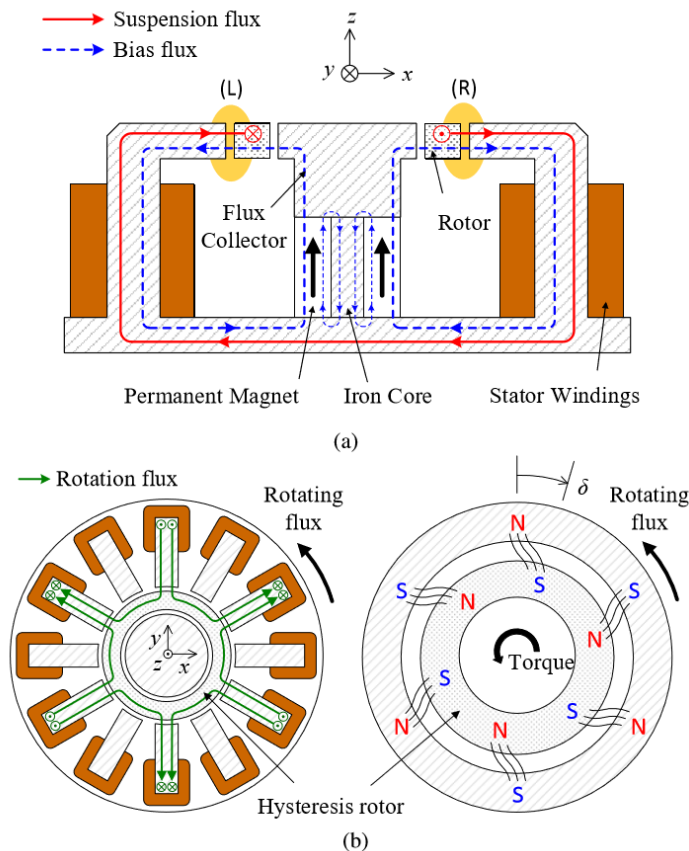
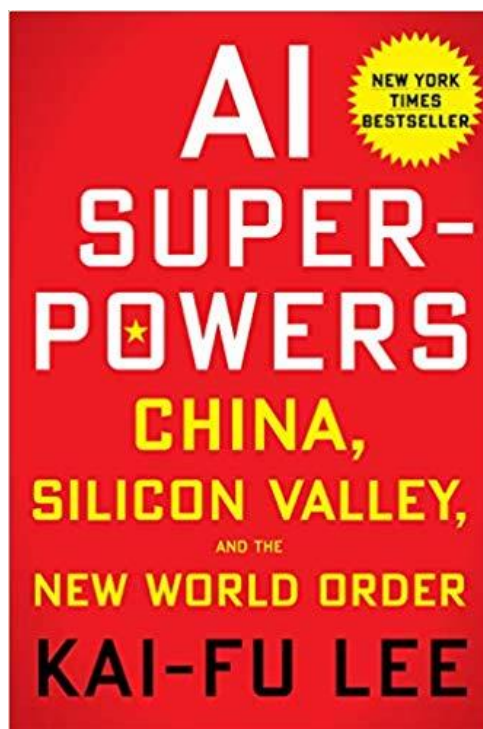

Fig. 2. Schematic diagram of the bearingless motor: (a) Cross-sectional side view illustrating the suspension force generation. The flux density of the air-gap (R) is stronger than that of the air-gap (L), thereby generating a reluctance force to the positive x -direction. (b) Top view illustrating the torque generation. The rotating 6-pole flux drags the rotor via an hysteresis coupling.

As ever, 'the field' wins. Asymmetric fields win bigger.

Best of the Month – AI SuperPowers



One of the scariest findings from our ongoing innovation research is the amount of innovation (i.e. ‘successful step-change’) that is meaningless. Products or services that make our lives more convenient at the expense of stripping away the things that are actually meaningful to our existence. About 75% of ‘innovations’ are currently falling in to this category, thanks in no small part to the rapid rise of Artificial Intelligence technologies.

That’s not to say that AI is necessarily a bad thing. Merely that, thus far, the AI pioneers are – logically, I suppose – chomping away at low-hanging fruit applications. The fact that some of this low hanging fruit (think about nearly every app on your smartphone) is actually not as low as the Silicon Valley wizards think, is merely ‘learning curve’. A lot of it, on the other hand, is already beginning to strip away a lot of the meaningless work that humans have had to do for the last couple of hundred years. AI is better than the best radiologists at picking up problems on an x-ray. AI is better at inspecting manufactured goods. At assembling cars. Diagnosing and curing patients is a highly meaningful act, but poring over x-rays with a magnifying-glass is not a meaningful part of the process. If the AI does that part of the job, the radiologist gets more time to focus on the meaningful stuff. The worst week of my life was my time as an apprentice in the Inspection Department at Rolls-Royce. Spending a week measuring a bucket of bolts to pick out the non-compliant ones, was about as meaningless as human jobs gets. Highly meaningful that non-compliant bolts were kept away from flying machines, but the moment a computer can do the quality measurement job better than the human operator, the human should have the option to be released to go and do something more meaningful instead.

This month’s Best-Of book is AI SuperPowers by Kai-Fu Lee. Dr. Lee is the chairman and CEO of Sinovation Ventures, a China based tech focused investment firm. Previous to becoming a full-time investor, Lee held positions at Google, Microsoft and Apple. A large part of that career, Lee spent working on data and AI, both in the US and in China. In “AI Superpowers—China, Silicon Valley and the New World Order” Lee bundles his

experiences and insights to describe the progress that China and the US have made and are making in the field of AI.

AI Superpowers contains a heap of valuable insights as well as predictions about the impact of technology power that both the US and China have been racking up in the journey to understanding how AI takes on the meaningless work and lets humans go back to being human.

One of the first things I take away from the book as a whole is the vital difference between American (i.e. Silicon Valley) and Chinese Government cultural views on the evolution of AI. Lee starts the book by writing about the contrasts in business culture between the US and China: “China’s startup culture is the yin to Silicon Valley’s yang: instead of being mission-driven, Chinese companies are first and foremost market-driven.” Lee goes on to explain that the ultimate goal of Chinese companies is “to make money, and they’re willing to create any product, adopt any model, or go into any business that will accomplish that objective.” This mentality helps to explain the ‘copycat’ attitude that Chinese companies have had historically. Meituan, for example, is a group-discount website which sells vouchers from merchants for deals which started as the perfect counterpart of US-based Groupon.

But then, more as a subtle undercurrent rather than overtly stated, it also seems clear that the Chinese Government view is that, while its really useful for Chinese entrepreneurship to flourish (‘some must get rich first’), this is merely a small part in a bigger jigsaw in which a potentially unruly population is kept under control (see the emerging Chinese ‘Social Credit’ system for a – to a Westerner at least – scary look at what I’m sure the Government ultimately gets out of all of their sponsorship of AI entrepreneurship).

When the Chinese Government says something will happen, it will happen. Some must indeed get rich first. And when told that ‘mass innovation’ and AI are the ways the Government wants people to get rich, what results is a tsunami of state-endorsed entrepreneurs. And an entrepreneurial ecosystem that will quickly swamp the capitalist reliance on the emergence of lone entrepreneurs. Especially when this gets combined with the mis-named ‘copycat’ mentality that China still has. Misnamed because what is happening in China is that any entrepreneur that comes up with a ‘good idea’ knows that it will very quickly be copied by others and the only sensible response to that fact is to keep coming up with more good ideas. An ecosystem full of ‘copycats’ means successful entrepreneurs have had to evolve to become ‘gladiators’. Silicon Valley deals with copycats by trying to sue them; China, by contrast, turns them into the best innovation accelerator ever. Take one of the emerging China-based image recognition startups, Face ++, which has quickly become a market leader in face / image recognition technology, leapfrogging the likes of Google, Microsoft and Facebook along the way. Why? Because what might have started off as ‘copying’ Silicon Valley ideas quickly turned into a fierce race to stay ahead of the copycats copying the copycats. ‘Even the bad stuff is good stuff’ in the China model... pure TRIZ.

Meanwhile, at the more detailed level, the book talks about “Online-to-Offline” (‘O2O’)—the conversion of online actions into offline services. Ride-sharing services like Uber and Lyft are great examples of the new O2O model. In China, Didi copied this model and tailored it to local conditions. Didi was followed by other O2O plays such as Dianping, a food delivery service which subsequently merged with the aforementioned Meituan company, and Tujia, a Chinese version of Airbnb. Lee also mentions WeChat and Alipay, describing how both companies completely overturned China’s all-cash economy. More recently, bike-sharing startups Mobike and ofo which supplied tens of millions of internet-

connected bicycles, distributing them across them about major Chinese cities and now across the globe. Dr Lee makes the compelling point that, because the China context has connected the online world to the offline world far more quickly than in the US or elsewhere, and because China has such a big population, the massive amount of real-world data this creates means O2O players probably already have an unassailable lead. The person with the data wins.

For a TRIZ person, or someone interested in S-Curves, perhaps the most important section of the book discusses ‘the four waves of AI’ and how the “AI revolution” will not happen overnight. Instead, AI will wash over us in four waves: internet AI, business AI, perception AI, and autonomous AI.

First wave: Internet AI—Internet AI is largely about using AI algorithms as recommendation engines: systems that learn our personal preferences and then serve up content hand-picked for us. Toutiao, sometimes called “the BuzzFeed of China”, is a great example of this first wave of AI; its “editors” are algorithms.

Second wave: Business AI—First wave AI leverages the fact that internet users are automatically labelling data as they browse. Business AI, the second wave of AI, takes advantage of the fact that traditional companies have also been automatically labelling huge quantities of data for decades. For instance, insurance companies have been covering accidents and catching fraud, banks have been issuing loans and documenting repayment rates, and hospitals have been keeping records of diagnoses and survival rates. Business AI mines these data points and databases for hidden correlations that often escape the naked eye and the human brain. RXThinking, an AI based diagnosis app, is a good example in this respect.

Third wave: Perception AI—Third wave AI is all about extending and expanding this power throughout our lived environment, digitising the world around us through the proliferation of sensors and smart devices. These devices are turning our physical world into digital data that can then be analysed and optimised by deep-learning algorithms. For example, Alibaba’s City Brain is digitising urban traffic flows through cameras and object-recognition. Compare this with the M4 roadworks that I’ve had to add an hour to my journey to Heathrow to get through for the last 8 months. The UK Government is ‘investing’ £848M in turning a 12 mile stretch of motorway into a ‘smart motorway’. It is doing it by digging up the roads and laying down literally tons of copper and fibre optic cable and sensors, when all the time the information needed to make the motorway ‘smart’ is already there in the Cloud. For the same money, City Brain could, I’m pretty certain, make every single road in the UK ‘smart’.

Fourth wave: Autonomous AI—Autonomous AI represents the integration and culmination of the three preceding waves, fusing machines’ ability to optimise from extremely complex datasets with their newfound sensory powers. This is the Wave – assuming Tolpuddle-like Martyrs don’t destroy the whole system – that will release humans from the meaningless and be allowed to get on with the meaningful. Or at least stay home and play on their X-boxes... although maybe not in China, where no doubt, ‘the system’ will know that you’re goofing off and need to be prodded into action to go and do something meaningful somewhere.

Political undercurrents aside, I found myself coming back to the high-level comment I made in my Systematic (Software) Innovation book: the IT geeks will control the future, but they’re the least qualified people – right now – to be trusted with the task. I’m certain this is still true. What I think Dr Lee’s book tells us is that, in the case of the Silicon Valley ‘yang’

(as proved every day by Zuckerberg) the people involved are still the least qualified. In the case of the Chinese Government, depending on your political ideology, we probably see the opposite. The exact 'most qualified' are pulling the strings. Whether that turns out to be a good thing or a bad thing depends on how prescient George Orwell's 1984 turns out to be. The 'Social Credit' system, as it inevitably evolves to its mature state, could either be mankind's savior or its downfall. It could deliver the 'higher level of meaning' that Marx was trying to describe or it could knock all the dominoes over. Interesting times. Essential reading.

Wow In Music – Shine On You Crazy Diamond



After writing *Dark Side of the Moon*, their most commercial album to date, the four members of Pink Floyd were introduced to all of the trappings of international stardom. It is perhaps no surprise, therefore that the band's next project would have an introspective theme. The 1975 album, *Wish you Were Here*, turned out to be exactly that kind of album. Listening back to the album today, the twin themes of absence and alienation are unmistakable. The album itself is built around the 'song' 'Shine On you Crazy Diamond', the lyrics of which pay homage to lost founder, Syd Barrett (**Shine on You crazy Diamond**). They have also become a source of considerable comfort to many people with depressive illnesses.

At over 26 minutes, *Shine on you Crazy Diamond* is Pink Floyd's longest single track. It is split into 2 halves, and then split again into 9 sections. The 1st half opens the album, the 2nd half is played at the end.

Steel Breeze

Roger Waters wrote all of the lyrics for *Shine on you Crazy Diamond*. They contain a succinct message built into only three short verses. Most of the ideas described in the lyrics are easy to understand.

"Remember when you were young, you shone like the sun" refers to Syd as he was growing up in Cambridge, a "bouncy" like character, full of passion.

"Now there's a look in your eyes, like black holes in the sky", is an obvious reference to Syd's state of mind during his mental decline. David Gilmour described it best in the "Syd Barrett Story" as a lack of his usual sparkle, the Syd he knew had gone.

"You were caught in the cross fire of childhood and stardom" exposed Syd Barrett's vulnerability on an emotional level as well as emphasising the attack and intrusion that sudden fame had caused him.

“You reached for the secret too soon”, a reference to Syd’s LSD drug use and its perceived (at the time) ability to help users reach a higher state of consciousness and spiritual understanding.

“You wore out your welcome with random precision”. This is a fantastic (Principle 37) oxymoron that sums up Syd’s alienation from Pink Floyd. “Random Precision” seems a very fitting phrase to describe Syd Barrett’s personality.

Then comes another, more subtle, (Principle 37) oxymoron, this time repeated at three points during the song. I think the idea in the lyric is that the “Steel Breeze” is both a metaphor for fame and the effects that it brings and also Barrett’s guitar playing. When the subject is first “blown on the steel breeze”, he has just become famous and is being subjected to all the forces and pressures that fame can exert. When he “rode on the steel breeze”, he was actively making use of his fame to further some of his own goals and desires. (This could easily ‘wear out his welcome’ if those goals are at odds with the agents of fame - photographers, agents, etc.) Finally, ‘basking in the shadows of yesterday’s triumph’, the heyday of his fame is behind him and all he can do is try to enjoy the residual effects of having once been famous, and “sail on the steel breeze”.

“Steel breeze” is, too, in many ways the essence of the Pink Floyd sound. Which is where, I believe much of the enduring appeal of Shine On You Crazy Diamond originates...

Parts I – IX (Music)

The music of Shine on you Crazy Diamond includes compositional elements from both lead instrumentalists, Dave Gilmour (guitar) and Rick Wright (keys). Gilmour wrote the famous 4 note motif (Bb – F – G – E) that enters 4 minutes into the song whereas Wright was responsible for some of the more complex harmonic structure, his signature “7#9” sound found on Breathe (Dark Side of the Moon), and several solos and funk grooves. One of the most musically interesting points is the use of a “Tierce de Picardie” ending, as the minor home key of G minor changes to the key of G major during the final few bars of the track.

Part I: Wright starts this journey with just a simple G minor chord played on a string sound and analogue pad; a mini moog is used to play a spacious atmospheric (Principle 2) time-signature-less soundtrack. This section lays the ambient foundation for the whole track.

Part II: At 2m 14s Gilmour enters the mix with similarly spacious guitar but this time the harmony changes between Gm, Dm and Cm. The placement of these chords implies that the accompaniment is following the guitar line using “colla voce”, a kind of rubato meaning literally “with voice”.

Part III – IV: Gilmour plays a 4-note arpeggio that is comprised of Bb – F - G (below Bb) - E that enters at 3m 59s. This phrase is repeated throughout the track and is later named the Syd Barrett theme. According to Gilmour’s words from subsequent interviews, the whole of Shine On You Crazy Diamond grew from this hypnotic, ‘bell-like’, phrase. The phrase is repeated 4 times before Nick Mason enters on drums, the feel is lazy 12/8 time, with Mason playing well behind the beat (Principle 37 in musical form), and the chord played is C major, different to the C minor that was used in parts I-II. The E note of the cell is sustained spelling the 3rd of C major, interestingly when the phrase is played under the solo form (which is basically a minor blues), the same E becomes the 6th of the Gm6 chord. This means that the Syd Barrett lick could be freely used across almost the whole of the solo section. It is only adapted to fit the harmony during the last bars (Eb7 – D7), where the E changes to Eb. This happens during Gilmour’s 1st solo.

Part V: The vocals enter at 8m 48s with verse 1. There is a sense of (Principle 12) antiphony between the vocal line and the guitar lead, and as a vital contrast to the

spacious opening, we hear a lyric with a syllable on almost every beat, making it near impossible to not listen to what is being said.

Church organ and gospel singers support the vocals especially when the lyric “Shine on you Crazy Diamond” is sung, raising the dynamic considerably (Principle 38). Dick Parry plays 2 choruses of improvised tenor saxophone, one at the original tempo and the second one where the feel (Principle 19) changes to a 4/4 shuffle using metric modulation giving the impression that the track is speeding up. This concludes the first half of Shine on as the sax solo fades over the tonic chord.

Part VI – VIII: Verse 3 is sung 5 minutes into the second half of the track after vamps based on straight 8th and shuffle grooves. At 6m 05s the meter changes again (Principle 19) to a slow 4, this time with a near disco feel. It’s just a Gm vamp but the orchestration includes the use of clavichord (a sound made popular by funk music) and electric piano. Layered on top of this vamp is a (Principle 5) pentatonic-based 4 bar synth riff that uses sweeping glissandi creating quite a haunting sound.

Part IX: A drum fill with a reversed effect plays a pickup into the part IX. At 9m 09 this is really the final anthem, the piece of music with a closing statement. We return to a slow 4 meter and a new sequence of chords with a more advanced flavour. The chord sequence is Gm – Bbm – Fm – Fm/Eb – Cm – Am7b5 – D7 and this is repeated 3 times before arriving at the “Tierce de Picardie” ending of G major. This last chord is significant as it leaves the listener with an optimistic feeling, a complete contrast to the rest of the track, which is essentially minor. The Steinway grand piano, organ, synths, and strings complement each other gloriously (Principle 40) and coupled with the slow tempo, there is a great sense of procession and then, finality.

Conclusion

Shine on you Crazy Diamond is a work of art and an extremely well-considered piece of music. The lyrics, the iconic 4-note arpeggio, the chord sequences, the changes in meter, the solo’s (where the presence of Barrett in both Gilmour and Wright’s playing is almost palpable), the unhurried true depiction of a story, the behind the beat drumming, the (Principle 3) changes in timbre all come together to make for an all-time classic. I first heard Shine On You Crazy Diamond at the start of punk rock, just after I read about Johnny Rotten walking around in his ‘I Hate Pink Floyd’ t-shirt. The radio DJ of choice for British punks back in the late 70s was the legendary, irreplaceable, John Peel. His annual listener-voted ‘Festive 50’ was always a great summary of the best music of the year. Punk or no-punk, for me the most amazing testament to the power of Shine On You Crazy Diamond is that it stayed at the top of the Festive 50 for several years. A beacon atop a sea of punk. Even those that were desperate to kick out the old guard, knew greatness when they heard it.

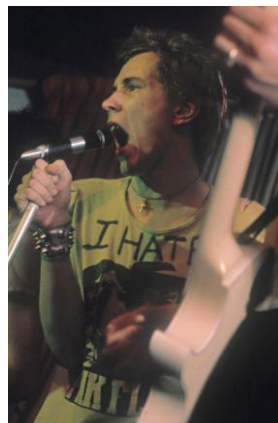

Investments – Breath Biopsy



A clinical trial has been launched to see if a breath test could detect the presence of cancer. Researchers want to find out if signals of different cancer types can be picked up in patterns of breath molecules. The Cancer Research UK team in Cambridge will collect breath samples from 1,500 people, some with cancer.

If the technology is proven, the hope is that breath tests could be used in GP practices to decide if patients need to be referred for more tests. They could potentially be used alongside blood and urine tests to help doctors detect cancer at an early stage, the researchers said.

How does the test work?

Molecules called volatile organic compounds (VOCs) are released when cells in the body carry out biochemical reactions as part of their behaviour. But if cancer or other conditions are present, the normal behaviour of cells is altered and they appear to produce a different pattern of molecules - and a different signature smell. The research team is trying to find out if this pattern or odour can be identified in people's breath, using breath biopsy technology. Their ultimate aim is to work out if different types of cancer produce different patterns - or signatures - which can be detected at an early stage.

What's the potential for the test?

This is the start of the trial so we won't know for several years whether or not the initial results are promising. The science behind the test itself is not new. Many researchers around the world have been working on the possibility of breath tests for a number of cancers, including lung, for a number of years. There are some promising signs that breath tests could detect pre-cancerous symptoms, but it is not yet clear how accurate they are. Any breath test used on large numbers of patients would have to be sensitive and accurate to avoid misdiagnoses and false positives. In short, there is a long way to go and much more research needed on more people before a breath test will be appearing in any GP surgeries.

More details: <https://www.owlstonemedical.com/products/>

Generational Cycles – Political Impressionability

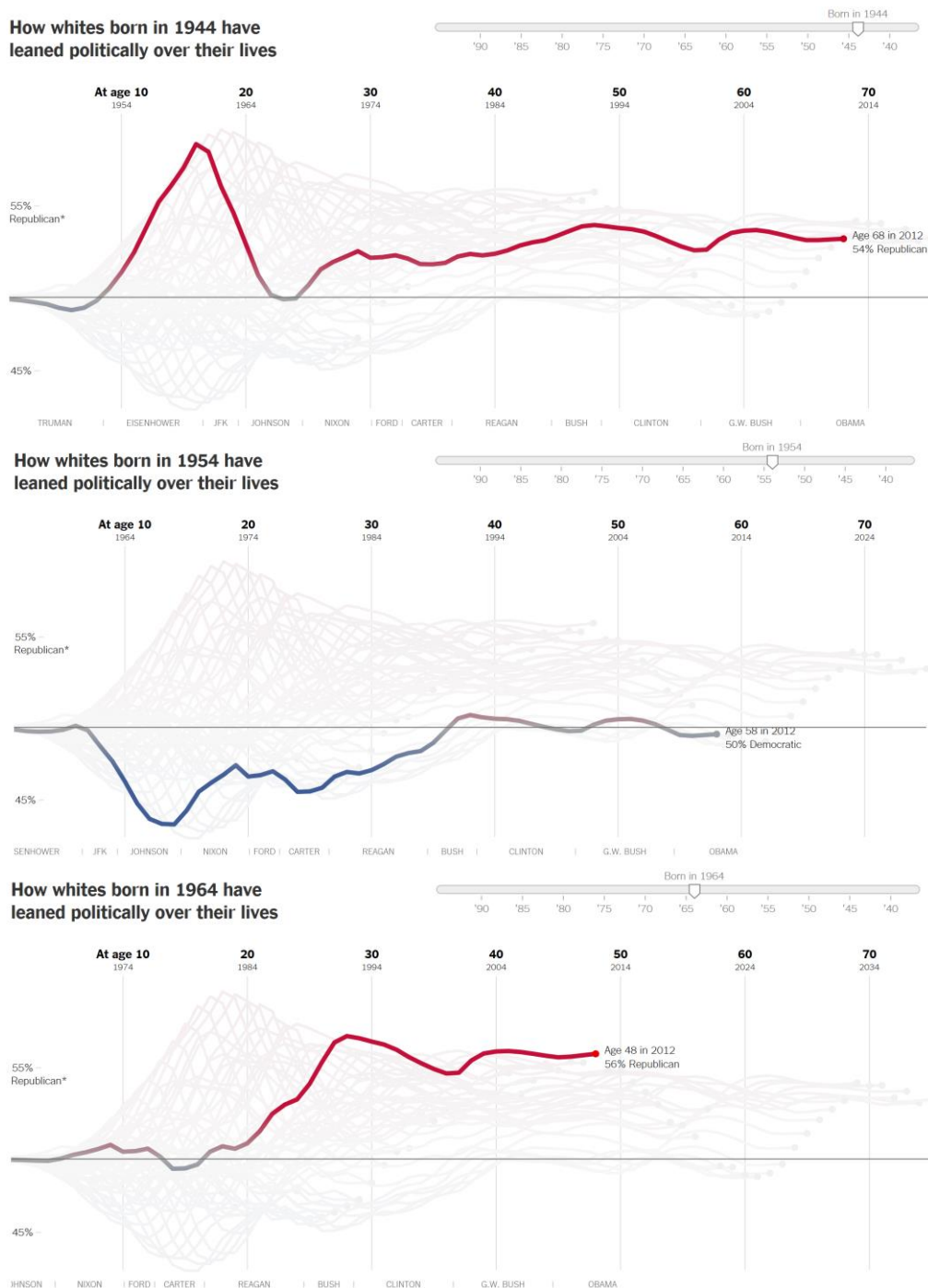

This from the Greg Lukianoff, Jonathan Haidt book, ‘The Coddling Of The American Mind’ (the one referenced earlier in the ezine in the second article):

“Here’s a quirk about American politics: the majority of white Americans vote for Republicans for president, unless they were born after 1981 or between 1950 and 1954.”

The most obvious generation-related connection is that ‘after 1981’ is all about the start of the Millennial, ‘Hero’ Generation. But the more interesting finding – especially if we stand by our research ethos of looking for things that don’t fit the theory – is what happened between 1950 and 1954, because at first glance, these years have little if any connection to any kind of generational transition period. The Lukianoff book continues...

“what’s the story for those born between 1950 and 1954? They strongly favoured Democrats through the 1980s and have roughly been evenly divided since then, with a slight lean overall toward the Democrats. Why is there a little demographic island of Democrats among white Americans born in the early 1950s?... The answer might be 1968. Or, rather, the period of emotionally intense national political events of 1968 and the years around it (roughly 1965-72). The political scientists Yair Ghitza and Andrew Gelman examined voting patterns of Americans to see whether political events or the political climate in childhood left some mark on people’s later political orientation. They found that there is a window of higher impressionability running from about age fourteen to twenty-four, with its peak around age eighteen. Political events – or perhaps the overall zeitgeist as people perceive it – are more likely to ‘stick’ during that period than outside that age range.”

The sequence of three graphics at the top of this article show the political affiliations of white Americans through their lives for people born in 1944, 1954 and 1964 respectively. (If you want to explore the graphic in more detail, check out www.nytimes.com/interactive/2014/07/08/upshot/how-the-year-you-were-born-influences-your-politics.html which is in its own right an amazing piece of data visualization.)

The core of the Strauss & Howe generation-cycle model contains two main parts. One, the transfer of influence from parent to child, and, two, ‘events happen at random, society’s reaction to those events is generationally conditioned’. What the Ghitza/Gelman research tells us is that our political reactions are ‘governed’ by what events happen when we’re in the age range 14 to 24:

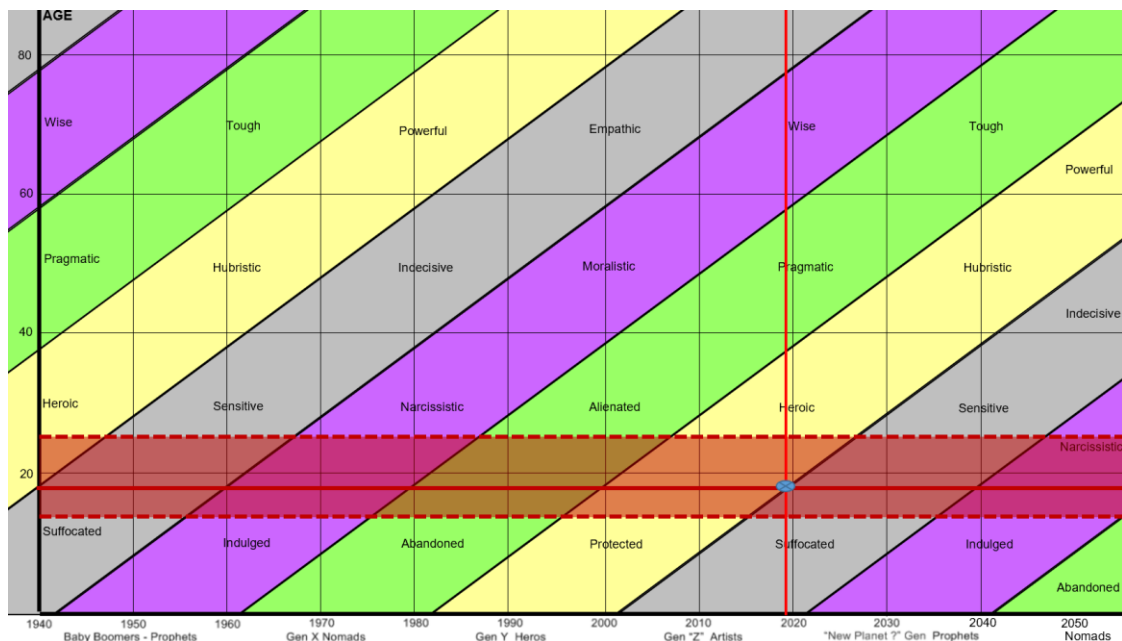

Two things come out of this picture:

- 1) Because the political ‘impressionability’ period of life is the ten years from 14 to 24, and generations are 20-25 years, it indicates that political affiliation – like popular music – is likely to follow a half-generation cyclical pattern.
- 2) More specifically, if we look at the blue dot on the graph it signifies a potentially important point in political history as the new ‘Generation Z Artists come of age. Looking at the political turmoil that’s been going on around them since 2016 it seems very likely we’ll see a significant leftward shift in their political views very much like those born in the 1950-1954 period. Which, if the same model applies in the UK (and we think it does), all those youngsters too young to vote in the Brexit referendum, might have something significant to say if there’s a second referendum now they’ve reached voting age.

Biology – Sailfish



The Atlantic sailfish (*Istiophorus albicans*) is a world-record holding speed merchant twice over. Early measurements of the sailfish's ability to move through the sea faster than any other marine vertebrate are currently the source of some challenge. What seems fairly clear, however, is that their short-burst top speed is indeed faster than any other fish. The initial view of the marine biologist community was that the capability was due to a pair of drag reduction features – one, the long, pointy snout, and the other, shark-like protrusions formed as part of the scales – and the fact that the enormous sail-like dorsal fin is retracted into a groove on the back of the fish so that it effectively disappears (an excellent example of both Principle 15, Dynamics, and 17, Another Dimension). The snout part of the story seems to now have been discounted from the drag-reduction equation and the growing consensus is that the biggest contribution to the high top speed record-breaking capability is the shape and musculature surrounding and just upstream of the tail fin. All in all, while we can see evidence of Principle 3, Local Quality in the scale-protrusions and caudal peduncles, what we're really looking at is an optimizing improvement over the characteristics of other high-speed fish (tuna, sharks, etc). The high burst-speed capability, in other words, is not the result of a solved-contradiction, just the gradual evolution towards an 'optimum' configuration.

The second 'high-speed' characteristic of the sailfish is the more interesting one. It does involve a contradiction-solving step-change. To see it, we need to look in more detail at why the sailfish's snout is so elongated: If the long, pointy feature has nothing to do with drag reduction, why has it evolved?

Sailfish eat primarily sardines and other types of shoal fish. Sardines have also evolved to swim at high speed. Because of their smaller size, they have the big advantage over the sailfish of being much more maneuverable. They can turn faster. So what does the sailfish do to overcome this relative lack of maneuverability speed deficiency?

Enter the snout. Quite literally. The main strategy of catching their prey involves the sailfish swimming up behind the shoal of whatever sardine-like prey it encounters. The narrow snout is able to 'enter' the shoal easily because it is long and thin. The snout enters the shoal. Some of the sardines at the rear, noticing a foreign object now swimming next to them, decide to change course. They dart rapidly in a direction away from the snout. The sailfish notices this deviation and immediately turns its head in the appropriate direction. In the time it takes for the sardine to move away, the sailfish can't

move its head by very much. But it only takes a small movement of the head to become, because the snout is rigidly attached to the head, a very large movement of the snout tip. The head turn rate has been measured at around 600degrees/second. Impressive in itself, but when we see the effect of this at the tip of the snout, it corresponds to a local speed of nearly 180m/s, or about 400mph.

So, in order to catch the maneuverable sardine, the sailfish needs to improve speed, and what makes that difficult are the forces required to do so. Here's what the contradiction looks like when mapped on to the Contradiction Matrix:

IMPROVING PARAMETERS YOU HAVE
SELECTED:

Speed (14) and Function Efficiency (24)

WORSENING PARAMETERS YOU HAVE
SELECTED:

Force/Torque (15)

SUGGESTED INVENTIVE PRINCIPLES:

13, 19, 3, 17, 35, 40, 15, 28, 29, 9, 18, 5,
7

Good to see Principle 17 high up on the list of contradiction-solving strategies. Another Dimension – i.e. evolve a long snout. Clever, sailfish-built Contradiction Matrix. Read more in this excellent paper: <https://royalsocietypublishing.org/doi/pdf/10.1098/rspb.2014.0444>

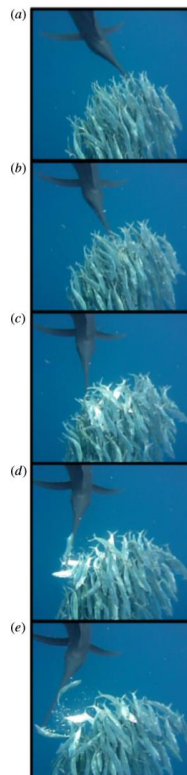
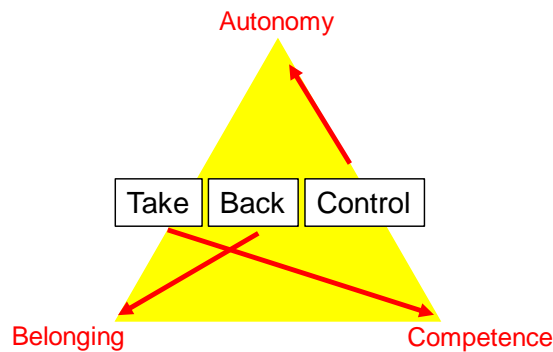

Figure 1. (a–e) A slashing sequence (interval between panels: 10 frames, i.e. 41.67 ms) of a sailfish 'slash' attack. In (c–e), the bill makes contact with at least five sardines and the detached scales from injured fish can be seen.

Short Thort

Slogans & Emotions

Brexit:



Trump:

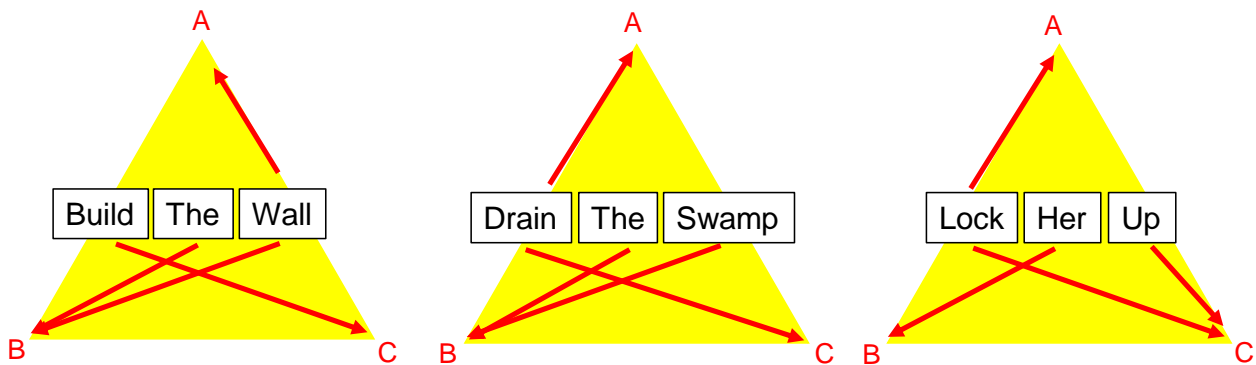

Red Bull:

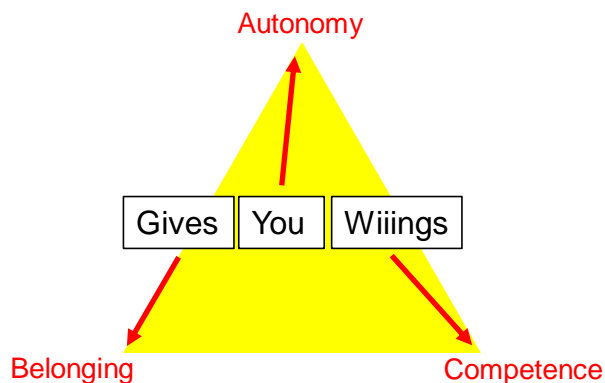

News

Sustainable Innovation 2019

Registrations are now open for the world's biggest sustainability-related innovation conference, which this year takes place in the UK. The Top 30" Abstracts, including Darrell's effort, 'Never Make Predictions, Especially About The Future: What TRIZ Tells Us About Sustainability In 2030' are now available for viewing via <http://cfsd.org.uk/events/sustainable-innovation-2019/abstracts/>.

ICSI'10

The 10th International Conference on Systematic Innovation, this year taking place at the University of Liverpool, has confirmed Darrell as a keynote speaker, and have asked him

to talk about, 'TRIZ And AntiFragile Systems'. He will also give a tutorial session on the last day of the conference, 'From Systematic To Systemic Innovation: Solving The Effectiveness-Versus-Simplicity Contradiction'. Registration is now open at <https://www.liverpool.ac.uk/events/event/?eventid=89547>.

ETRIA TRIZ Future Conference

It may well be a record-breaking year as far as our attendance at TRIZ events is concerned. Here's Number two. The 2019 TFC conference – now the world's biggest – will be held in Marrakech, Morocco from the 9th to 11th of October. Darrell's abstract is already in the system, the deadline for which is 1 February (although, if this year ends up being similar to previous years, it will likely be extended, the TRIZ community being probably the world's worst for doing anything on time). Still, at least the conference website was on time... more details here: <http://tfc19.ma/>

TRIZ Summit

And here's Number Three. Darrell nearly fainted when he was asked to keynote at the big 'Soviet' TRIZ conference, which this year will be held in Minsk, Belarus from 13 to 15 June. More details and registration here: <https://events.epam.com/events/triz-summit-2019-eng>

InsureTech

Darrell is speaking at an Executive Breakfast for the UK insurance industry at Cardiff University on 19 February. Assuming that goes well, and we don't scare everyone to death about the industry's collective lack of innovation capability and imminent threat from the AI Superpowers (see earlier book review), we'll then be running a one day 'Systematic Innovation For Insurance' workshop on 29 April. More details from Darrell or the Cardiff University Business School website.

USA

We will be back in North America at least twice this year. An 'emergency' event in Minneapolis in March, and jobs in Minneapolis and Orlando in May. Which might also mean that (Number Four) Darrell will get to go to the Altshuler Institute, TRIZCON event taking place at Purdue University in Indiana from the 20th to the 22nd. Details here: <https://www.aitriz.org/>

New Projects

This month's new projects from around the Network:

- Transport – Technology Scouting
- Agriculture – Design-Make Project
- Government – Entrepreneurship Mentoring Programme
- Retail – Consumer Anthropology Study
- Biomed – Strategic Study
- O&G – SI Certification Workshops
- O&G – Strategic Problem-Solving Project
- O&G – SI Distance-Learning Platform Development